

PRODUCT NUMBER
SEE TABLE

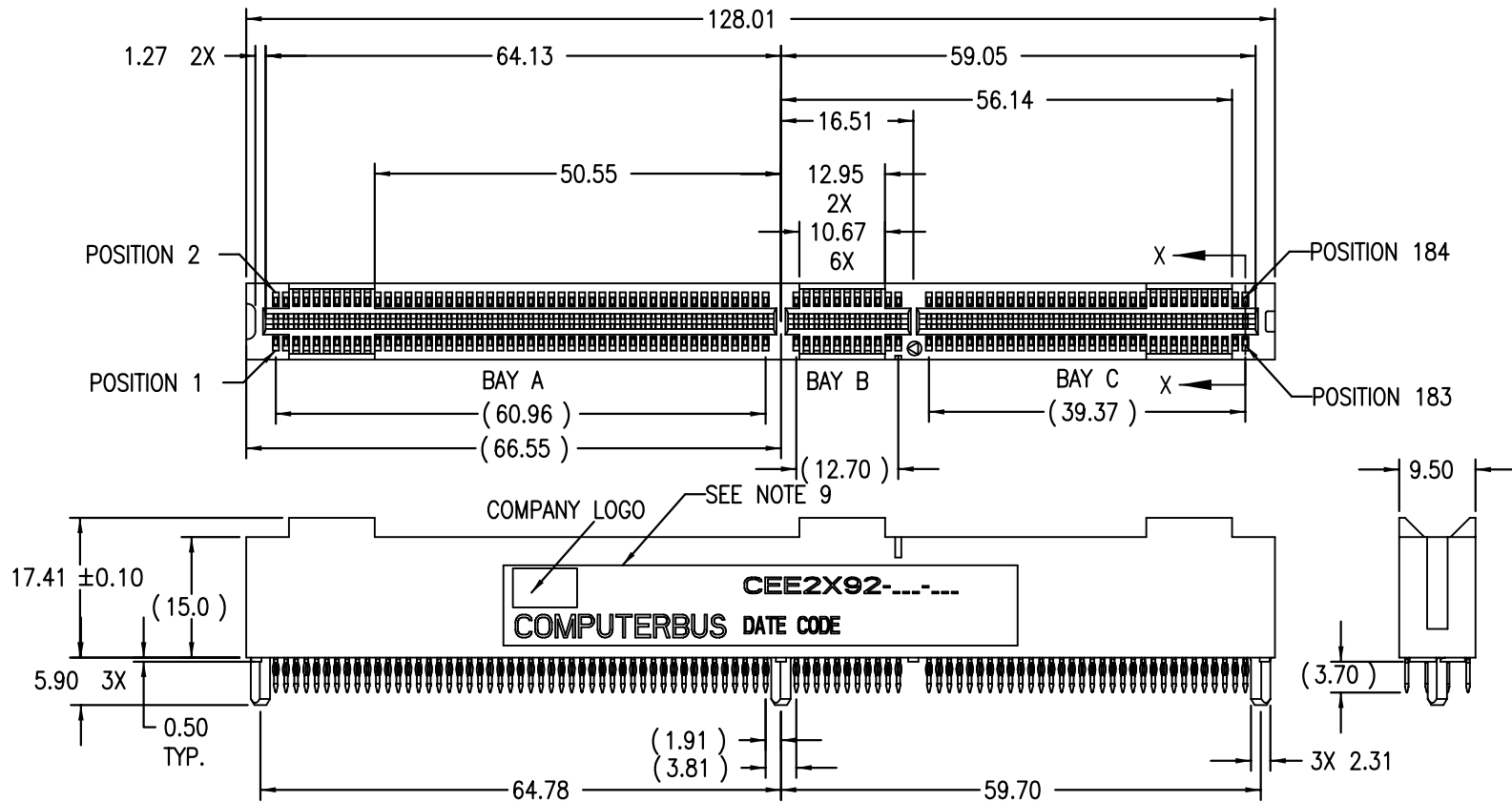

CEE2X92PF-102PY4, CEE2X92PF-102PY4LF SHOWN, FULLY LOADED
 CEE2X92PF-153PY4, CEE2X92PF-153PY4LF SIMILAR, EXCEPT FOR LOAD PATTERN
 CEE2X92PF-102Z56, CEE2X92PF-102Z56LF FULLY LOADED
 CEE2X92PF-153Z56, CEE2X92PF-153Z56LF SIMILAR, EXCEPT FOR LOAD PATTERN
 CEE2X92PF-102PY4W, CEE2X92PF102PY4WLF SHOWN, FULLY LOADED

mat'l. code				surface ISO 1302	tolerance ISO 406 ISO 1101	projection	product family CARDEDGE
ltr	ec'n no	dr	date	tolerances unless otherwise specified		MM	title CEE 2X92 PF CONNECTOR ASSEMBLY
AC	M06-0037	MHT	3/30/06	angles	linear		
AD	M06-0234	AGS	06/16/06			scale 6:5	dwg no SE96947
AE	M06-0325	MHT	8/24/06	0°±1°			sheet 1 of 7 size A3
AF	M06-0427	AGS	10/26/06	dr	G. PETERS	9/18/01	type Product Customer Drawing
AG	M06-0445	AGS	11/06/07	engr	D. CASEY	9/21/01	
AH	M07-0075	MHT	1/25/07	chr	G. PETERS	9/18/01	
AJ	M08-0224	MHT	8/13/08	appd	D. CASEY	9/18/01	
sheet	revision	AJ	AJ	AJ	AJ	AJ	
index	sheet	1	2	3	4	5	6

PRODUCT NUMBER
SEE TABLE

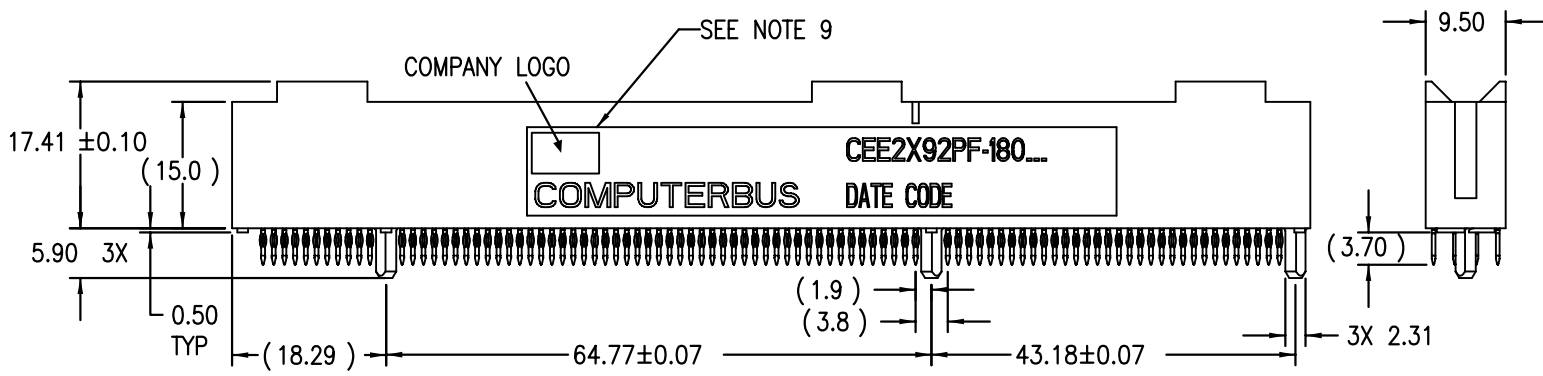
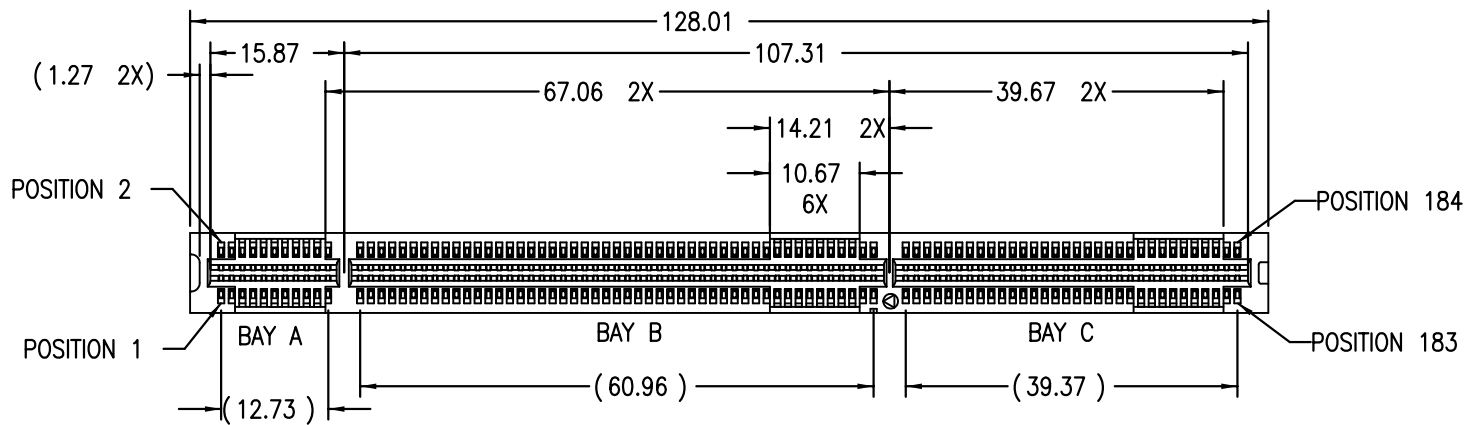

CEE2X92PF-180PY4, CEE2X92PF-180PY4LF CONNECTOR SHOWN
 CEE2X92PF-180Z56, CEE2X92PF-180Z56LF FULLY LOADED
 CEE2X92PF-180PY4W, CEE2X92PF180PY4WLF CONNECTOR SHOWN

mat'l. code		surface ISO 1302		tolerance ISO 406 ISO 1101		projection MM		product family CARDEDGE	
ltr	ec'n no	dr	date	tolerances unless otherwise specified					
AJ				angles	linear	.X±.2	title CEE 2X92 PF CONNECTOR ASSEMBLY		
				0°±1°		.XX±.10	dwg no SE96947		
						.XXX±.050	sheet 2 of 7 size A3		
				dr	G. PETERS	9/18/01	type Product Customer Drawing		
				enr	D. CASEY	9/21/01			
				chr	G. PETERS	9/18/01			
				appd	D. CASEY	9/18/01			
sheet	revision								
index	sheet								

FCI CATALOG NO. f/CONNECTORS w/CARD COLLECTORS	CONNECTOR SIZE	NO. CONTACTS LOADED	TERM.	LOAD PATTERN UNPOPULATED POSITIONS	CONTACT PAIRS BAY A	CONTACT PAIRS BAY B	CONTACT PAIRS BAY C
CEE2X92PF-102PY4	2x92	184	P.F.	FULLY LOADED	49	11	32
CEE2X92PF-102PY4W	2x92	184	P.F.	FULLY LOADED	49	11	32
CEE2X92PF-180PY4	2x92	184	P.F.	FULLY LOADED	11	49	32
CEE2X92PF-180PY4W	2x92	184	P.F.	FULLY LOADED	11	49	32
CEE2X92PF-153PY4	2x92	159	P.F.	2,4,5,9,10,11,12,13,14,29,30,31,32,51,52,53,54,155,156,157,158,159,160,161,162	49	11	32
CEE2X92PF-102Z56	2x92	184	P.F.	FULLY LOADED	49	11	32
CEE2X92PF-180Z56	2x92	184	P.F.	FULLY LOADED	11	49	32
CEE2X92PF-153Z56	2x92	159	P.F.	2,4,5,9,10,11,12,13,14,29,30,31,32,51,52,53,54,155,156,157,158,159,160,161,162	49	11	32
CEE2X92PF-102PY4LF	2x92	184	P.F.	FULLY LOADED	49	11	32
CEE2X92PF102PY4WLF	2x92	184	P.F.	FULLY LOADED	49	11	32
CEE2X92PF-180PY4LF	2x92	184	P.F.	FULLY LOADED	11	49	32
CEE2X92PF180PY4WLF	2x92	184	P.F.	FULLY LOADED	11	49	32
CEE2X92PF-153PY4LF	2x92	159	P.F.	2,4,5,9,10,11,12,13,14,29,30,31,32,51,52,53,54,155,156,157,158,159,160,161,162	49	11	32
CEE2X92PF-102Z56LF	2x92	184	P.F.	FULLY LOADED	49	11	32
CEE2X92PF-180Z56LF	2x92	184	P.F.	FULLY LOADED	11	49	32
CEE2X92PF-153Z56LF	2x92	159	P.F.	2,4,5,9,10,11,12,13,14,29,30,31,32,51,52,53,54,155,156,157,158,159,160,161,162	49	11	32

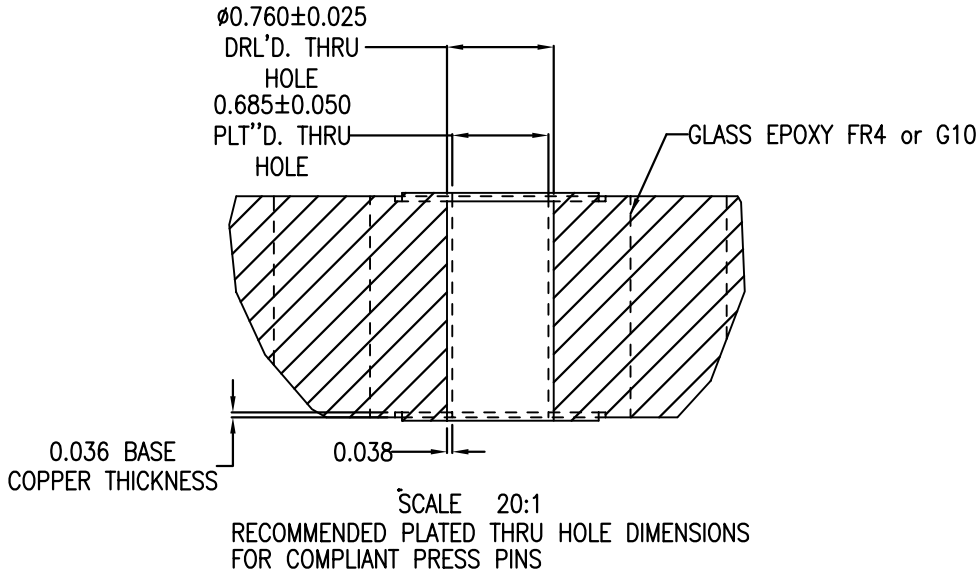
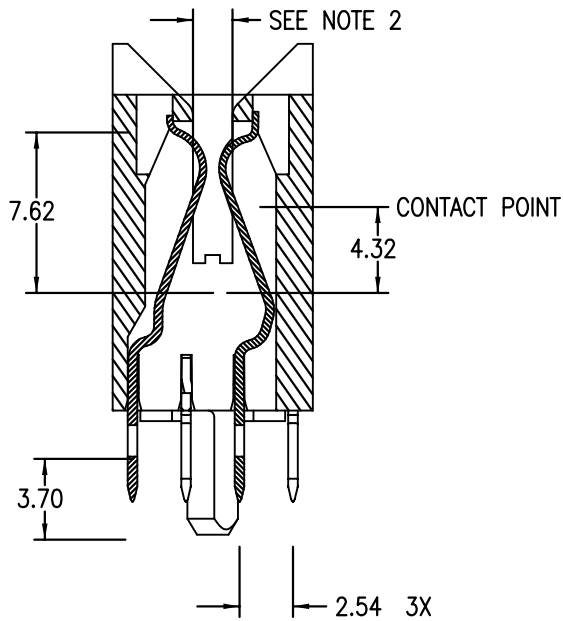

mat'l. code		surface ISO 1302	tolerance ISO 406 ISO 1101	projection	product family CARDEDGE
ltr	ecr no	dr	date	tolerances unless otherwise specified	title
AJ				linear .X±.2 .XX±.10 .XXX±.050	CEE 2X92 PF CONNECTOR ASSEMBLY
				angles 0°±1°	scale 6:5
				dr G. PETERS 9/18/01	dwg no sheet 3 of 7 size
				enr D. CASEY 9/21/01	SE96947 A3
				chr G. PETERS 9/18/01	type Product Customer Drawing
				appd D. CASEY 9/18/01	
sheet	revision				
index	sheet				

PRODUCT NUMBER
SEE TABLE

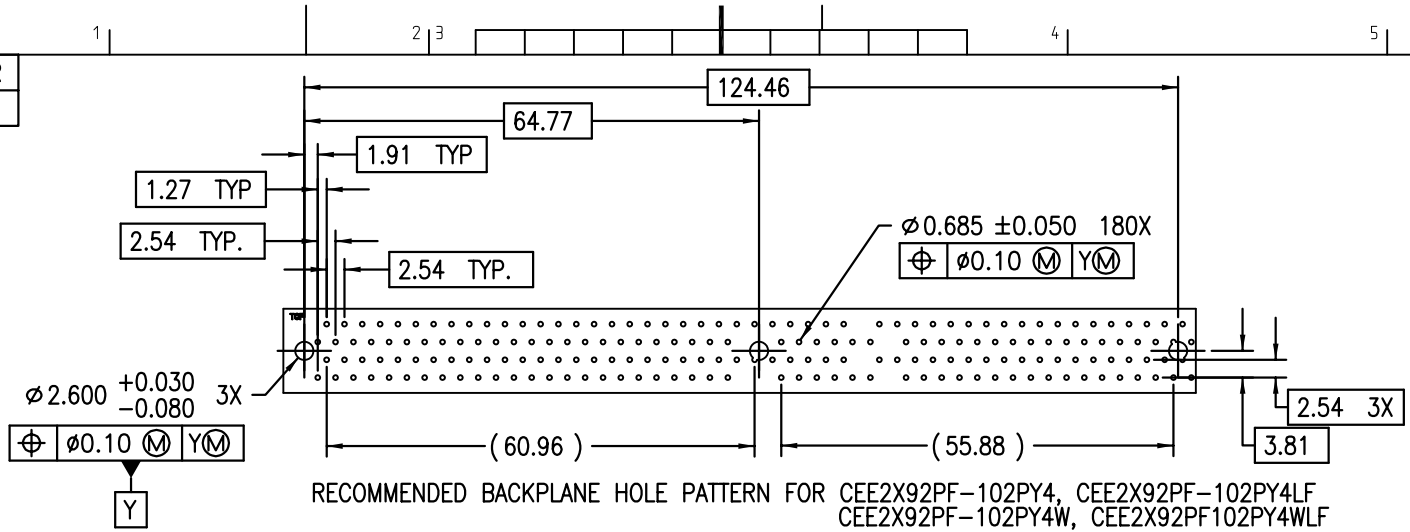

RECOMMENDED BACKPLANE HOLE PATTERN FOR CEE2X92PF-102PY4, CEE2X92PF-102PY4LF
CEE2X92PF-102PY4W, CEE2X92PF102PY4WLF
CEE2X92PF-153PY4, CEE2X92PF-153PY4LF
CEE2X92PF-102Z56, CEE2X92PF-102Z56LF
CEE2X92PF-153Z56, CEE2X92PF-153Z56LF

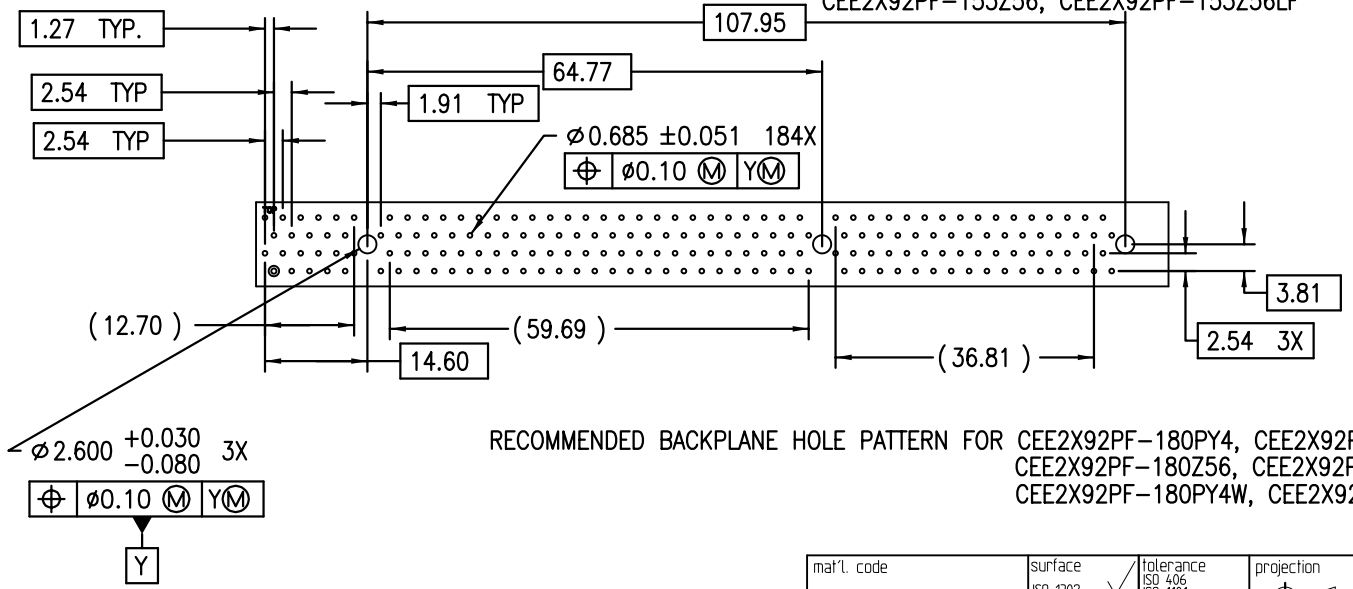

RECOMMENDED BACKPLANE HOLE PATTERN FOR CEE2X92PF-180PY4, CEE2X92PF-180PY4LF
CEE2X92PF-180Z56, CEE2X92PF-180Z56LF
CEE2X92PF-180PY4W, CEE2X92PF180PY4WLF



Copyright FCI

mat'l. code		surface ISO 1302	tolerance ISO 406 ISO 1101	projection 	product family CARDEDGE
ltr	ecn no	dr	date	tolerances unless otherwise specified	title
AJ				.X±.2 linear .XX±.10 .XXX±.050	CEE 2X92 PF CONNECTOR ASSEMBLY
				angles 0°±1°	MM scale 1:1
				dr G. PETERS 9/18/01	dwg no sheet 4 of 7 size
				enr D. CASEY 9/21/01	SE96947 A3
				chr G. PETERS 9/18/01	type Product Customer Drawing
				appd D. CASEY 9/18/01	
sheet	revision				
index	sheet				

PRODUCT NUMBER
SEE TABLE

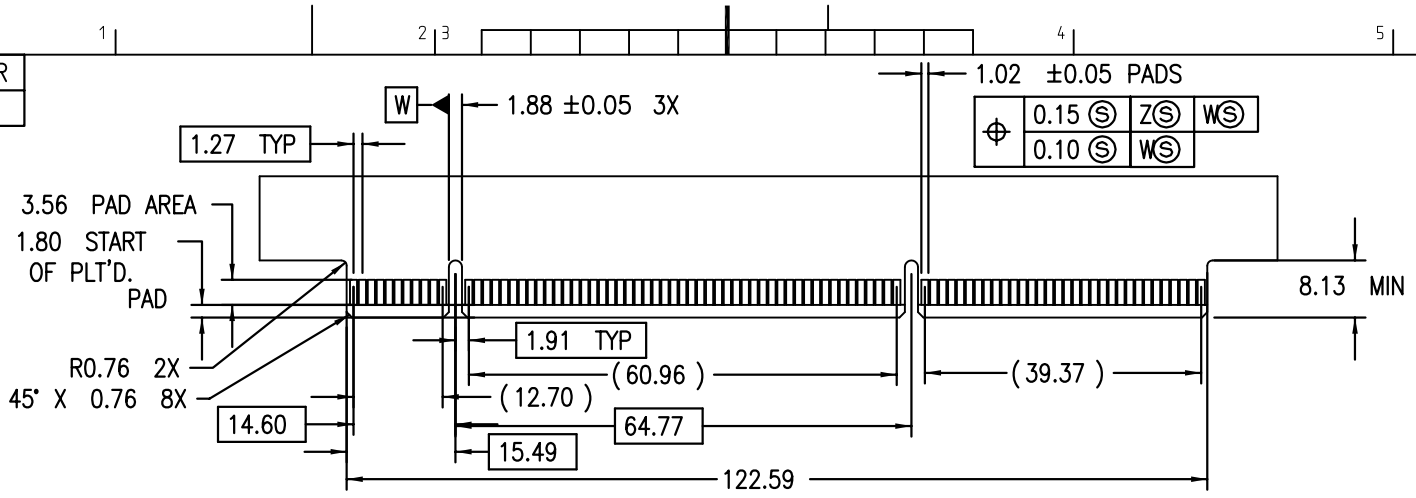

RECOMMENDED BACKPLANE COMPONENT PCB FOR CEE2X92PF-180PY4, CEE2X92PF-180PY4LF
FOR CEE2X92PF-180Z56, CEE2X92PF-180Z56LF
CEE2X92PF-180PY4W, CEE2X92PF180PY4WLF

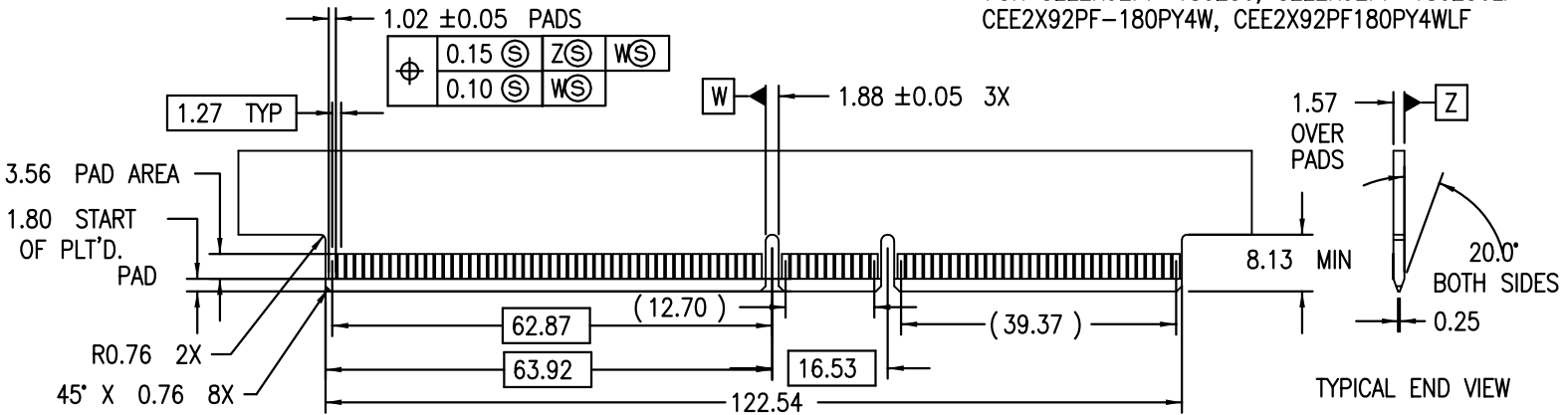

RECOMMENDED BACKPLANE COMPONENT PCB FOR CEE2X92PF-102PY4, CEE2X92PF-102PY4LF
CEE2X92PF-102PY4W, CEE2X92PF102PY4WLF
CEE2X92PF-153PY4, CEE2X92PF-153PY4LF
CEE2X92PF-102Z56, CEE2X92PF-102Z56LF
CEE2X92PF-153Z56, CEE2X92PF-153Z56LF

mat'l. code		surface ISO 1302		tolerance ISO 406 ISO 1101		projection		product family CARDEDGE	
ltr	ec'n no	dr	date	tolerances unless otherwise specified		title		CEE 2X92 PF CONNECTOR ASSEMBLY	
AJ				angles	linear	MM		sheet 5 of 7 size	
				0°±1°	.X±.2 .XX±.10 .XXX±.050	scale 1:1		A3	
		dr	G. PETERS	9/18/01	FCJ		dwg no		SE96947
		enr	D. CASEY	9/21/01			type		Product Customer Drawing
		chr	G. PETERS	9/18/01					
		appd	D. CASEY	9/18/01					
sheet	revision								
index	sheet								

PRODUCT NUMBER

SEE TABLE

NOTES:

1. INTERPRET THIS DRAWING IN ACCORDANCE WITH ANSI Y14.5M -1982.
2. CONNECTORS WITH CARD COLLECTING SCOOPS ARE DESIGNED TO ACCOMMODATE 1.57+/- .180 PC BOARDS WITH WARPAGE UP TO +/-2.03.
3. RECOMMENDED COMPONENT BOARD MATERIAL:
P.C. BOARD:FR-4 WITH 28.35 GRAMS MIN. COPPER, PADS PLATED WITH .76 MICRONS MIN GOLD, PER MIL-G-45204, TYPE 1, CLASS 1, GRADE C OVER 2.54 MICRONS MIN NI. UNDERPLATE PER QQ-N-290.
4. RECOMMENDED BACK PLANE THICKNESS IS 2.39 FOR 3.71 COMPLIANTAIL.
5. CONTACT MATING SURFACES ARE LUBRICATED WITH OS-138.
6. MATERIAL:

BODY: POLYPHTHALAMIDE (PPA) UL RATED 94V-0
COLOR, BLACK
LIQUID CRYSTAL POLIMER (LCP) 30% GF
COLOR, NATURAL

CONTACTS: PHOS BRONZE, PER FCI SPEC. M738

CONTACT FINISH:
PY4 MAY BE EITHER 0.76 MICRONS GOLD OR 0.76 MICRONS GXT PLATED AT MANUFACTURER'S OPTION IN CRITICAL CONTACT AREA
1-3/ MICRONS TIN/LEAD OVER 1.27 MICRONS Ni UNDERPLATE ON CONTACT TAILS.

Z56 0.40 MICRONS GOLD OVER 2.00 MICRONS Ni UNDEERPLATE IN CRITICAL CONTACT AREA. 1-3 MICRONS TIN/LEAD OVER 2.00 MICRONS Ni UNDERPLATE ON PRESSFIT TAILS.

LEAD FREE OPTION:

PY4 MAY BE EITHER 0.76 MICRONS GOLD OR 0.76 MICRONS GXT PLATED AT MANUFACTURER'S OPTION IN CRITICAL CONTACT AREA
1-3 MICRONS TIN OVER 1.27 MICRONS Ni UNDERPLATE ON CONTACT TAILS.

Z56 0.40 MICRONS GOLD OVER 2.00 MICRONS Ni UNDEERPLATE IN CRITICAL CONTACT AREA. 1-3 MICRONS PURE TIN OVER 2.00 MICRONS Ni UNDERPLATE ON PRESSFIT TAILS.

7. PERFORMANCE CHARACTERISTICS: SEE SHEET 7.
8. ITEM NAME, LOGO, PART NUMBER, DATE CODE, AND UL SYMBOLS TO BE DISPLAYED IN THIS AREA NATURAL COLOR CONNECTOR ONLY WILL HAVE DATE CODE DISPLAYED
9. LF SUFFIX AT THE END OF PART NUMBER IS LEAD FREE OPTION. NATURAL COLOR CONNECTOR ONLY WILL HAVE DATE CODE DISPLAYED.
EXAMPLE: CEE2X92PF-180PY4LF
LEAD FREE OPTION.
10. THIS PRODUCT MEETS EUROPEAN UNION DIRECTIVES AND OTHER COUNTRY REGULATION AS DESCRIBED IN GS-22-008.
11. PART NUMBERS WITH "W" AT THE END OR "W" BEFORE "LF" ARE MOLDED IN NATURAL COLOR.



Copyright FCI

mat'l. code		surface ISO 1302		tolerance ISO 406 ISO 1101		projection 		product family CARDEDGE	
ltr	ecn no	dr	date	tolerances unless otherwise specified				title	
AJ				angles	linear			CEE 2X92 PF CONNECTOR ASSEMBLY	
				0°±1°		scale 1:2		dwg no	
				dr	G. PETERS	9/18/01		sheet 6 of 7 size	
				engr	D. CASEY	9/21/01		SE96947	
				chr	G. PETERS	9/18/01		A3	
				appd	D. CASEY	9/18/01		type Product Customer Drawing	
sheet	revision								
index	sheet								

PRODUCT NUMBER

SEE TABLE

PERFORMANCE CHARACTERISTICS: "PY4 PLATED CONTACTS ONLY"
 ENVIRONMENTAL:

OPERATING TEMPERATURE: -40C TO 105C
 THERMAL SHOCK: EIA-364 TP32, -55C TO +85C, 5 CYCLES

FLAMABILITY RATING: UL94V-0

MECHANICAL:

DURABILITY: 100 MATING CYCLES WITHOUT PHYSICAL DAMAGE, OR EXCEEDING LOW LEVEL CONTACT RESISTANCE REQUIREMENTS WHEN MATED WITH RECOMMENDED CARD.

CONTACT RETENTION: EIA-364 TP29, 4.4 N MIN.

MATING FORCE: EIA-364 TP13 2.0 N MAX. AVERAGE PER OPPOSING PAIR USING GAUGE PER MIL-STD-C-21097 WITH CARD PROFILE

CONTACT NORMAL FORCE: 0.72 N MINIMUM

PRESS FIT TERMINATION FORCES: INSERTION FORCE 70 N MAX. PER PIN
 RETENTION FORCE 9 N MIN. PER PIN

ELECTRICAL:

CONTACT RESISTANCE: EIA-364 TP45, WITH 10 MILLIOHM MAX. INITIAL, 20 (LOW SIGNAL LEVEL) MILLIOHM RISE. COMPONENT BOARD SIDE - 1 MILLIOHM MAX., CONNECTION PRESS FIT PIN WITH w/PLATED THROUGH HOLE.

INSULATION RESISTANCE: MIL-STD-202, METHOD 302, CONDITION B, 1000 MEGAOHMS MIN.

DIELECTRIC WITHSTAND VOLTAGE: EIA-364 TP45 CONDITION 1, 500 VAC RM

CAPACITANCE: 2 PICO FARADS, MAX AT 1 MEGAHERTZ

CURRENT RATING: 1 AMP, 30C RISE ABOVE AMBIENT

VOLTAGE RATING: 150 VAC (RMS)



Copyright FCJ

mat'l. code				surface ISO 1302 <input checked="" type="checkbox"/>		tolerance ISO 406 ISO 1101		projection 		product family CARDEDGE			
ltr	ec'n no	dr	date	tolerances unless otherwise specified						title			
AJ				angles	linear	.X±.2		MM		CEE 2X92 PF CONNECTOR ASSEMBLY			
				0°±1°		.XX±.10		scale 1:2		dwg no SE96947			
						.XXX±.050				sheet 7 of 7 size A3			
				dr	G. PETERS	9/18/01				type Product Customer Drawing			
				enr	D. CASEY	9/21/01							
				chr	G. PETERS	9/18/01							
				appd	D. CASEY	9/18/01							
sheet	revision												
index	sheet												